



Description

600lbs Double EM locks were designed to meet fire/life safety applications by providing an auxiliary locking mechanism that has no moving parts to bind or wear out for trouble free operation. This will ensure inhibited release at all times where they have become extremely prevalent in applications other than fire/ life safety. Suitable for access controlled & secure areas within buildings with double leaf doors.

Standard Features



Life Safety Applications



No Residual



Low Energy Consumption



Cost Savings

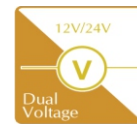

12/24V Selectable (Optional)



Ideal for all door type

Dimension :

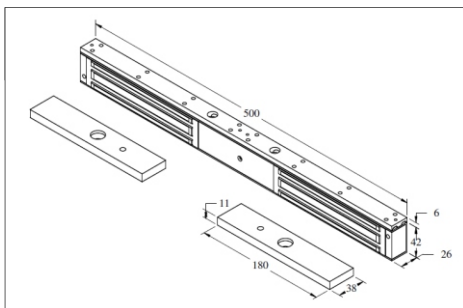

Specification

	UL275-D
Magnet Size	500 X 42 X 26 mm
Armature Size	180X 38gXg11 mm
Holding Force	Up to 600lbs x 2
Current Drain	480mA±10%/12Vdc / 240mA±102/24Vdc
Temperature	(-10 to 55) ^o C (14 to 131) ^o F
Weight	3.7kg

WARRANTY: - EM Lock are warranted against defects in material and workmanship while used service for a period of 1 year from the date of sale to the original customer.

DISCLAIMER: - Specifications are subject to change without prior notice.
- Attached photo is for reference purpose only, actual product may varies.