



#### Description

600lbs EM locks were designed to meet fire/life safety applications by providing an auxiliary locking mechanism that has no moving parts to bind or wear out for trouble free operation. This will ensure inhibited release at all times where they have become extremely prevalent in applications other than fire/ life safety. Suitable for access controlled & secure areas within buildings.

#### Standard Features



Life Safety Applications

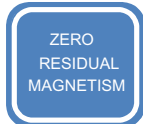

No Residual



Low Energy Consumption



Cost Savings

#### Extended Features

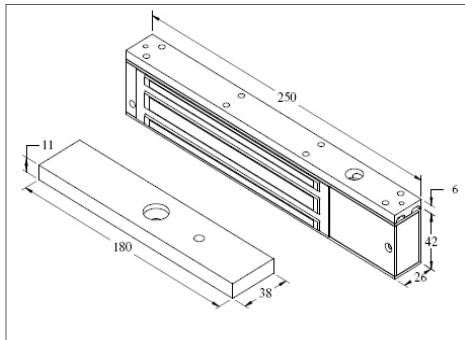

#### Specification

	EML-UL275C-SP
<b>Magnet Size</b>	250 X 42 X 26 mm
<b>Armature Size</b>	180 X 38 X 11 mm
<b>Holding Force</b>	Up to 600lbs
<b>Current Drain</b>	480mA±10V/12Vdc
<b>Temperature</b>	1-10 to 552°C 114 to 1312°F
<b>Weight</b>	2.0kg

**WARRANTY:-** EM Lock warranted against defects in material and workmanship while used in normal service for a period of 1 year from the date of sale to the original customer

**DISCLAIMER:-** Specifications are subject to change without prior notice